



**International Shooting Sport  
Federation  
And  
USA SHOOTING**



## **RIFLE RULES**

**FOR**

**300m Rifle**

**300m Standard Rifle**

**50m Rifle**

**10m Air Rifle**

---

Edition 2013 (Second Print 1/2014)

Effective 1 January 2014



## CHAPTERS

7.1	GENERAL .....	- 323 -
7.2	SAFETY .....	- 323 -
7.3	RANGE AND TARGET STANDARDS .....	- 323 -
7.4	RIFLES AND AMMUNITION .....	- 323 -
7.5	CLOTHING REGULATIONS .....	- 331 -
7.6	SHOOTING EVENT PROCEDURES AND COMPETITION RULES .....	- 341 -
7.7	RIFLE EVENTS .....	- 342 -
7.8	300m SCORING AND MARKING PROCEDURES – PAPER TARGETS .....	- 343 -
7.9	RIFLE EVENT TABLE .....	- 345 -
7.10	RIFLE SPECIFICATION TABLE .....	- 346 -
7.11	INDEX .....	- 350 -

### NOTE:

Where figures and tables contain specific information, these have the same authority as the numbered rules.



## 7.1 GENERAL

7.1.1 These Rules are part of the ISSF Technical Rules and apply to all Rifle events.

7.1.2 All athletes, team leaders and officials must be familiar with the ISSF Rules and must ensure that these Rules are enforced. It is the responsibility of each athlete to comply with the Rules.

**USA 7.1.2A** All shooters, team leaders and officials must be familiar with all USA Shooting rules and must ensure that these rules are enforced.

7.1.3 When a Rule refers to right-handed athletes, the reverse of that Rule refers to left-handed athletes.

7.1.4 Unless a Rule applies specifically to a men's or a women's event, it must apply uniformly to both men's and women's events.

## 7.2 SAFETY

### SAFETY IS OF PARAMOUNT IMPORTANCE

ISSF Safety Rules are found in Rule 6.2.

## 7.3 RANGE AND TARGET STANDARDS

Target and target standards are found in Rule 6.3. Requirements for ranges and other facilities are found in Rule 6.4.

## 7.4 RIFLES AND AMMUNITION

### 7.4.1 Standards for All Rifles

7.4.1.1 **Single Loader Rifles.** Only single shot rifles that must be manually loaded before each shot may be used, except that in the 300m Standard Rifle Event a rifle that is legal for use in International Military Sport Council (CISM) 300m rifle events may be used if it is checked by Equipment Control before the event.

7.4.1.2 **One Rifle Per Event.** Only one (1) rifle is allowed to be used in the Elimination, Qualification and Finals Rounds of one (1) event. The action, barrel and stock may not be exchanged, except that a detachable butt-stock may be exchanged. Accessories attached to the action, barrel or stock may be exchanged. A rifle that becomes disabled may be replaced according to Rule 6.13.3, if the Jury approves.

7.4.1.3 **Movement or Oscillation Reduction Systems.** Any device, mechanism or system that actively reduces, slows or minimizes rifle oscillations or movements before the shot is released is prohibited.

**(USAS Clarification:** This does not preclude barrel weights. It is an active device that indicates when approaching the center of the target.Example: device used by blind shooters)



**7.4.1.4 Pistol Grips.** The pistol grip for the right hand must be constructed in such a way that it does not rest on the sling or on the left arm.

**7.4.1.5 Barrels** and extension tubes must not be perforated in any way. Compensators and muzzle brakes on rifles are prohibited. Any construction or device inside the barrel or tubes, other than rifling and chambering for the cartridge or pellet, is prohibited.

**7.4.1.6 Sights**

- a) Corrective lenses and telescopes must not be attached to the rifle;
- b) Corrective lenses or eyeglasses, and/or filters or tinted lenses, may be worn by the athlete;
- c) Any sight not containing a lens or system of lenses or other means of optical enhancement is permitted, except that light or polarizing filters may be fitted to the front or rear sight, or both;
- d) Any aiming device programmed to activate the firing mechanism is prohibited;
- e) A blinder may be attached to the rifle or to the rear sight. The blinder must not be more than 30 mm deep (A) nor extend further than 100 mm (B) from the center of the rear sight aperture on the side of the non aiming eye. A blinder must not be used on the side of the aiming eye; and

**Rear Sight Blinder**

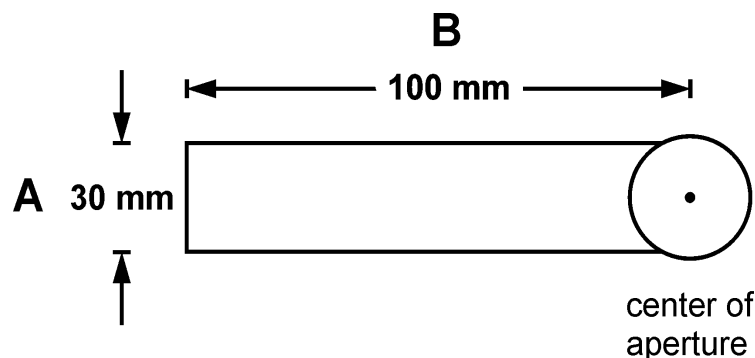

- f) A prism or mirror device may be used when shooting from the right shoulder while aiming with the left eye, providing it does not have a magnifying lens or lenses. It must not be used when shooting from the right shoulder when using the right eye.

**7.4.1.7 Electronic triggers** are allowed providing:

- a) All components are firmly attached to and contained within the action or stock of the rifle so that the battery and wires are not visible externally;
- b) The trigger is operated by the right hand of a right-handed or the left hand of a left-handed athlete;
- c) All components are included when the rifle is submitted for inspection by Equipment Control; and



- d) The rifle with all components installed complies with the rules governing dimensions and weight for that event.

## 7.4.2

### Standards for 300m Standard Rifle and 10m Air Rifle

#### 7.4.2.1

The butt plate may be adjustable up or down. The lowest point of the stock or toe of the butt plate, with the butt plate in its maximum downward position must not exceed 220 mm from the centerline of the barrel. It may be offset parallel to the centerline of the normal end of the butt plate left or right a maximum 15 mm OR the complete butt plate (not part) may be turned on the vertical axis.

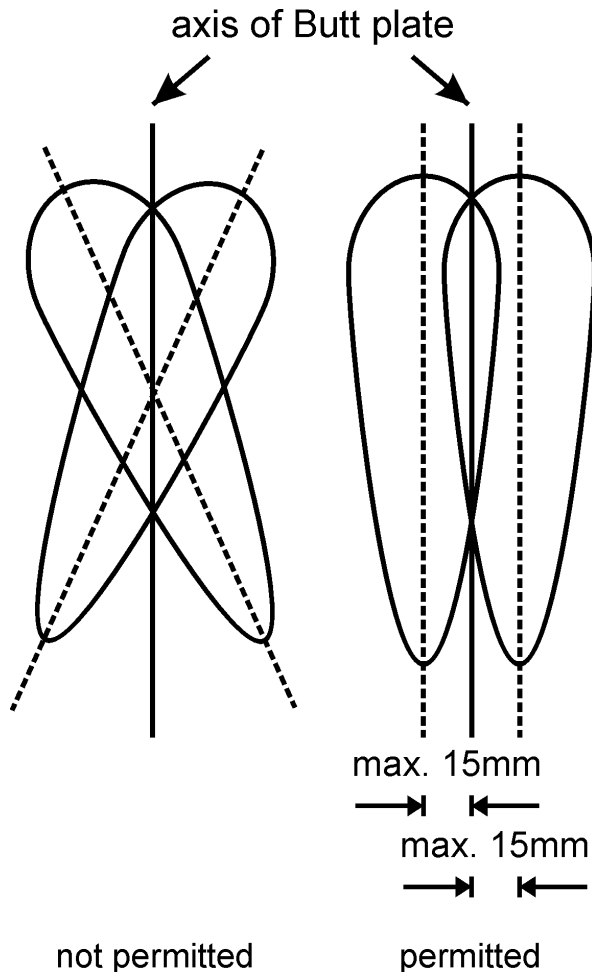

Turning the butt plate on the horizontal axis is not permitted.

#### 7.4.2.2

A thumb hole, thumb rest, palm rest, heel rest and spirit level are prohibited. A heel rest is any protrusion or extension on the front or side of the pistol grip designed to prevent the hand from slipping.

#### 7.4.2.3

If a stock is less than the maximum allowed in any dimension, it may be brought up to the measurements shown in the **Rifle Measurements Table**. Any addition must be within the permitted dimensions and in no case may the pistol grip, cheek-piece or lower part of the stock be anatomically formed.

#### 7.4.2.4

The pistol grip must not extend more than 60 mm from a vertical plane that is perpendicular to the centerline of the barrel.



**7.4.2.5** Material that gives increased grip may not be added to the forend, pistol grip or lower part of the stock.

**7.4.2.6 Weights**

- a) Barrel weights within a radius of 30 mm from the center of the barrel are permitted. Barrel weights may be moved along the barrel;
- b) Any other weights must be within the dimensions of the stock; and
- c) Any devices or weights projecting forward or laterally from the lower part of the butt plate are prohibited.

**7.4.3 Standards for 300m Standard Rifle Only**

All 300m Standard Rifles must conform to the specifications shown in the Rifle Measurements Table and with the following restrictions:

- a) The minimum trigger pull is 1500 grams. The trigger pull must be measured with the barrel in a vertical position. Trigger weight control checks must be conducted immediately after the last series. A maximum of three (3) attempts to lift the weight are allowed. Any athlete whose rifle fails the test must be disqualified;
- b) The rifle must not be removed from the firing line during the course of fire except with the permission of range officials;
- c) The same rifle must be used in all positions without change. The adjustment of the butt plate and hand stop or the changing of front sight inserts or the adjustment of the rear sight or its eyepiece are permitted. The removal of the cheek piece during competition is permitted for barrel cleaning and bolt removal under supervision of the Jury; but its position must not be changed when it is replaced; and
- d) The overall length of the barrel including any extension tube, measured from the breech face to the apparent muzzle, must not exceed 762 mm.

**7.4.4 Standards for 10m Air Rifle Only**

Any type of compressed air or gas rifle that conforms to the specifications in the **Rifle Measurements Table** and the following additional restrictions:

- a) The total length of the air rifle system measured from the back end of the mechanism to the apparent muzzle must not exceed 850 mm; and
- b) The front sight may not extend beyond the apparent muzzle.



### 7.4.4.1 Rifle Measurements Table

Front sight not to extend beyond the apparent muzzle

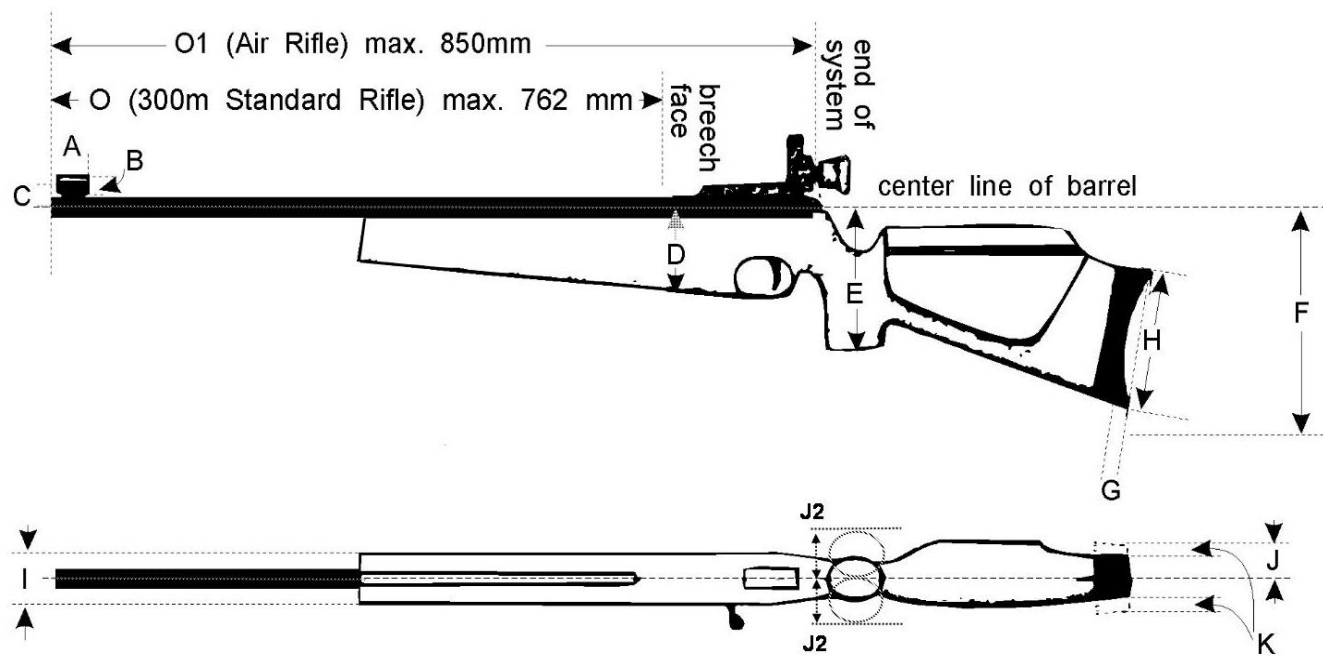



**Measurements for Dimensions C, D, E, F, and J, are from the Centerline of the Barrel**

<b>Key</b>	<b>RIFLE FEATURE</b>	<b>300m Standard Rifle</b>	<b>Air Rifle</b>
A	Length of front sight tunnel	50 mm	50 mm
B	Diameter of front sight tunnel	25 mm	25 mm
C	Distance from center of the front sight ring or top of post to center of bore either directly above or offset (except for those athletes firing from the right shoulder but using their left eye).	60 mm	60 mm
D	Depth of fore-end	90 mm	90 mm
E	Lowest point of pistol grip	160 mm	160 mm
F	Lowest point of stock or toe of butt plate with the butt plate in its maximum downward position	220 mm	220 mm
G	Depth of curve of butt plate	20 mm	20 mm
H	Heel to toe length of butt plate	153 mm	153 mm
I	Maximum thickness (breadth) of fore-end	60 mm	60 mm
J1	Maximum distance of cheek piece from a vertical plane perpendicular to the centerline of the barrel	40 mm	40 mm
J2	Maximum distance of any part of the pistol grip from a vertical plane perpendicular to the centerline of barrel	60 mm	60 mm
K	Offset of butt plate parallel to the centerline of the normal end of the butt left or right.	15 mm	15 mm
L	Trigger weight - No Set Trigger	1500 grams minimum	Free
M	Weight with sights (and hand stop 300m)	5.5 kg	5.5 kg
N	The front sight must not extend beyond the apparent muzzle of the rifle of both, 300m Standard or Air Rifle	Must not extend	Must not extend
O	Standard Rifle: The overall length of the barrel including extension (from the muzzle to the breech face)	762 mm	---
O1	Air Rifle: Total length of the Air Rifle system	---	850 mm





#### 7.4.5

#### Standards for 50m Rifles

All rifles chambered for rimfire 5.6 mm (.22" cal.) Long Rifle cartridges are permitted:

- a) The weight of the rifle may not exceed 8.0 kg for men with all accessories used including palm rest or hand stop;
- b) The weight of the rifle may not exceed 6.5 kg for women, with all accessories used including the palm rest or hand stop;
- c) Weights on or in the lower part of the stock or butt-stock, may not extend horizontally further from the centerline of the barrel than the distance of the maximum extension of the cheek-piece from the centerline of the barrel. Weights cannot extend further to the rear than a line perpendicular to the deepest point in the butt plate; and
- d) Weights on the rifle fore-end may extend no lower than 90 mm below the centerline of the barrel and not further forward than 700 mm from the back (rear) end of the system.

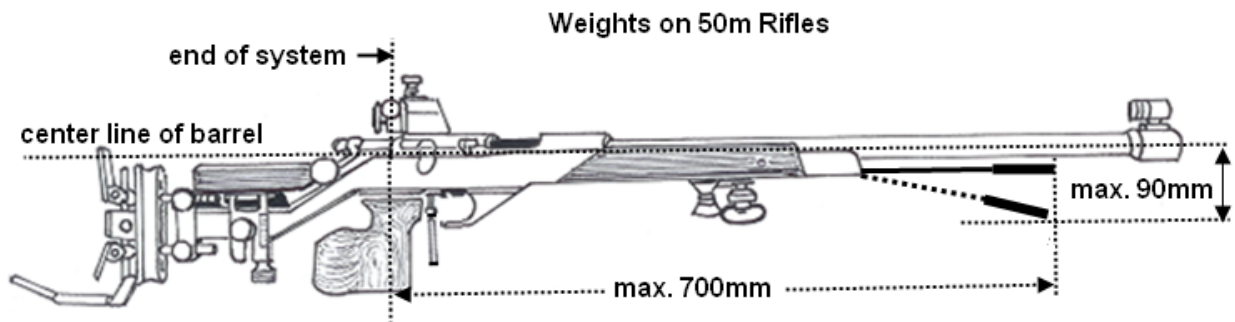

Weights on the fore-end of the rifle may extend no lower than 90mm below the center line of the barrel and not further forward than 700mm from the back (rear) end of the system



#### 7.4.5.1

#### Butt Plate and Hook

- a) A butt hook that complies with the following restrictions may be used;
- b) The butt hook projecting rearward from the bottom of the butt plate must not extend more than 153 mm (A) past the rear of a line that is perpendicular to a line drawn through the axis of the bore of the rifle, and that is tangent to the deepest part of the butt plate depression that normally rests against the shoulder;
- c) The butt hook projecting from the bottom of the butt plate must have a total outside length around any curve or bend of not more than 178 mm (B);
- d) The top projection of the butt plate must not extend more than 25 mm to the rear of this perpendicular line; and
- e) Any devices or weights projecting forward or laterally from the lower part of the butt plate are prohibited.

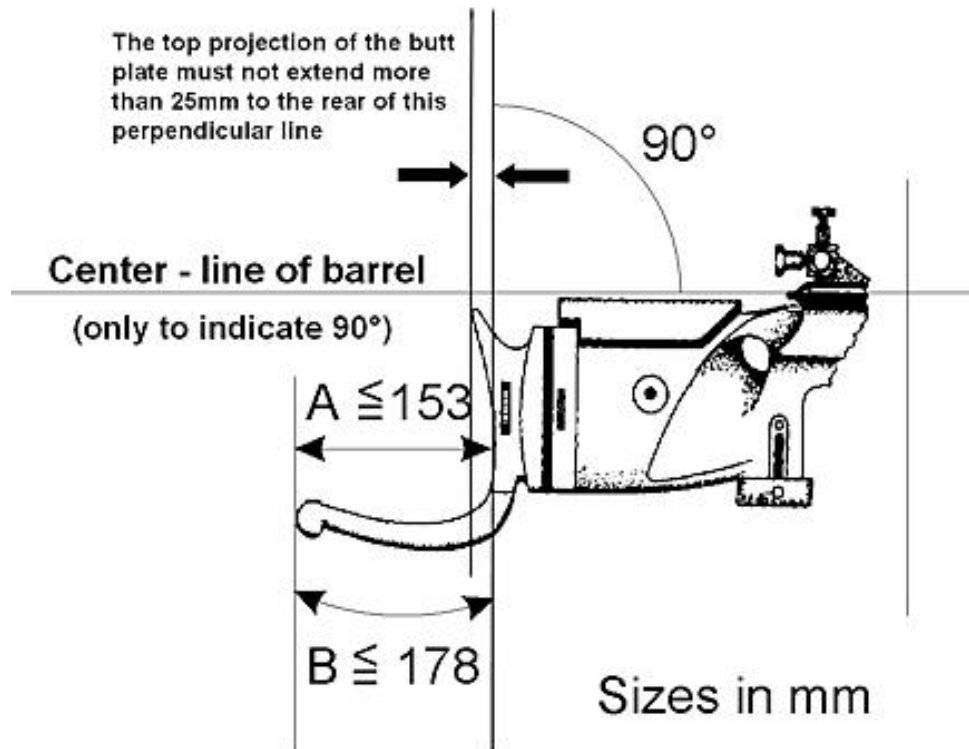

#### 7.4.5.2

#### Palm Rests

A palm rest is any attachment or extension below the fore-end that aids the support of the rifle by the forward hand in the standing position only. Such extensions must not extend more than 200 mm below the centerline of the barrel.

#### 7.4.5.3

#### Pistol Grips

No part of the pistol grip may be extended or constructed in any way that would allow it to touch or support the back of the hand.



#### 7.4.5.4 Standards for 300m Rifles

Standards for 300m Rifles are the same as for the 50m Rifle (men and women). See 7.4.5 and the **RIFLE SPECIFICATION TABLE**.

#### 7.4.6 Ammunition

Rifle	Caliber	Other specifications
50m	5.6 mm (.22")	Rimfire Long Rifle. Only bullets made of lead or similar soft material are permitted.
10m	4.5 mm (.177")	Projectiles of any shape made of lead or other soft material are permitted.
300m	Maximum 8 mm	Ammunition of any description that may be fired without any danger to athletes or range personnel. Tracer, armor piercing, and incendiary ammunition is prohibited.

### 7.5 CLOTHING REGULATIONS

See the General Technical Rules for general standards regarding clothing and the testing of clothing (Rule 6.7).

#### 7.5.1 General Standards for Rifle Clothing

##### 7.5.1.1

All shooting jackets, shooting trousers and shooting gloves must be made of flexible material that does not materially change its physical characteristics, that is, become stiffer, thicker or harder, under commonly accepted shooting conditions. All lining, padding and reinforcements must meet the same specifications. Any lining or padding must not be quilted, cross-stitched, glued or otherwise affixed to the outer clothing layer other than at normal tailoring points. All lining or padding must be measured as a part of the clothing.

##### 7.5.1.2

Only one (1) shooting jacket and only one (1) pair of shooting trousers may be used by each athlete in all Rifle events in any ISSF Championship. All rifle shooting jackets and shooting trousers must have a seal with a unique serial number issued by ISSF Equipment Control and registered in an ISSF database. Athletes with jackets or trousers that do not have a seal must bring them to Equipment Control to have a seal attached and registered in the ISSF database. Only one jacket and one trouser may be registered to each athlete. Athletes with more than one jacket or trousers with ISSF seals must inform the ISSF Equipment Control which item will be used in future competitions and only one seal per item will remain. Athletes that change jackets or trousers or any with no seal (new or changed) must bring them to Equipment Control to obtain a seal and retire the previous seal (6.7.7.1.f). When an athlete is selected for post-competition testing, the test must confirm that the seal number registered to that athlete was the seal number on the clothing used by that athlete.



**7.5.1.3** Ordinary athletic type training trousers or normal athletic type training shoes may be worn in any event or position. If shorts are worn during competitions, the bottom of the leg must be no more than 15 cm above the center of the kneecap. Sandals of any type may not be worn.

**7.5.1.4** Athletes are responsible for ensuring that all items of clothing used by them comply with these Rules. The Equipment Control Section must be open to make voluntary inspections of athletes' clothing from the Official Training day until the last day of Rifle competition and athletes are encouraged to bring their rifle clothing items for an Equipment Control check before the competitions to be sure they comply with these Rules. In preparing jackets and trousers for competitions, athletes must make allowances for any measurement variations that may occur because of changes in temperature, humidity or other environment conditions.

**7.5.1.5** Post-competition checks will be made of all Rifle clothing items after Elimination and Qualification Round competitions to ensure compliance (6.7.6).

**7.5.2 Clothing Measurement Standards**

**7.5.2.1 Clothing Thickness Standards Table**

Rifle competition clothing must comply with these thickness measurement standards:

Measurement Location	Thickness	Jackets	Trousers	Shoes	Gloves	Underwear
Normal	Single	2.5 mm	2.5 mm	4.0 mm	—	2.5 mm
Normal	Double	5.0 mm	5.0 mm	—	—	5.0 mm
Normal	Total	—	—	—	12.0 mm	—
Reinforcements	Single	10.0 mm	10.0 mm	—	—	—
Reinforcements	Double	20.0 mm	20.0 mm	—	—	—

No measurement greater than the thickness measurement standards in the chart may be approved (zero tolerance).

**7.5.2.2 Stiffness Measurement Standards**

Rifle competition clothing must comply with these stiffness measurement standards:

- a) If the measuring cylinder is depressed at least 3.0 mm, the material is acceptable;
- b) If a measurement below 3.0 mm is displayed, the material is too stiff. No measurement below the minimum measurement of 3.0 mm may be approved; and
- c) Every part of the jacket or trousers must be capable of being measured with the 60 mm measuring cylinder. If a part is too small for normal testing (no flat area 60 mm or larger), measuring must be done over the seams.



### 7.5.2.3 **Shoe Sole Flexibility Standard**

The soles of athletes' shoes must bend at least 22.5 degrees when a force of 15 Newton-Meters is applied to the heel area while the boot or shoe is clamped in the testing device (See Rule 6.5.3).

(USAS Clarification: Shooting shoe flexibility will not be adopted. Athletes making any USAS teams will be expected to comply with this rule before any travel with the team.)

### 7.5.3 **Shooting Shoes**

Normal street type or light athletic shoes are permitted in all positions. Special shooting shoes not exceeding the following specifications may be worn only in 10m and 50m 3 Positions events. Special shooting shoes must not be worn in Rifle Prone events:

**7.5.3.1** The material of the upper part (above the line of the sole) must be of soft, flexible, pliable material, not thicker than 4 mm, including all linings, when measured on any flat surfaces such as point D in the **Shooting Shoe Measurements Table** (7.5.3.6).

**7.5.3.2** The shoe sole must be constructed of the same material and composition throughout its length and breadth and the sole must be flexible in the entire forward part of the foot. Athletes may use removeable inner soles or inserts in their shoes, but any inserts must also be flexible in the forward part of the foot.

**7.5.3.3** To demonstrate that soles are flexible, athletes must walk normally (heel-toe) at all times while on the FOP. A warning will be given for the first offense, a two-point penalty and disqualification will be given for subsequent violations.

**7.5.3.4** The height of the shoe from the floor to the highest point (Dimension C, **Shooting Shoe Measurements Table**) must not exceed two thirds (2/3) of the length.

**7.5.3.5** If an athlete wears shoes, they must be a matched pair externally.

(USAS Clarification: Shooting shoe measurements will not be adopted. Athletes making any USAS teams in will be expected to comply with this rule before any travel with the team.)



### 7.5.3.6

### Shooting Shoe Measurements Table

Athletes shoes must not exceed the maximum dimensions shown in the drawing and chart:

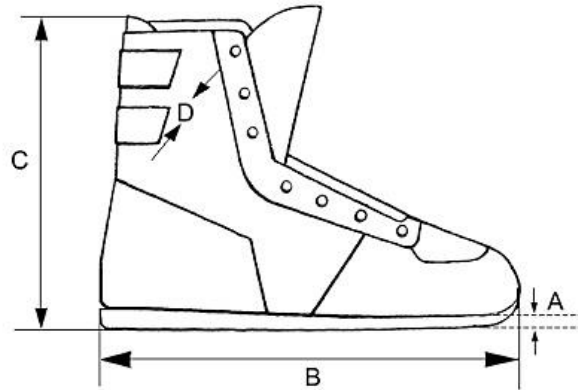

A.	Maximum thickness of sole at the toe: 10 mm.
B.	Overall length of shoe: According to size of wearer's foot.
C.	Maximum height of shoe: Not to exceed two-thirds (2/3) length of B.
D.	Upper part of shoe material maximum thickness 4 mm.
The shoe sole must follow the external curvature of the shoe and may not extend more than 5.0 mm beyond the external dimensions of the shoe at any point. Toes or heels may not be cut square or flat.	



## **7.5.4 Shooting Jacket**

**7.5.4.1** The body and sleeves of the jacket, including the lining, must not exceed 2.5 mm in single thickness and 5.0 mm in double thickness at any point where flat surfaces may be measured. The jacket must not be longer than the bottom of the balled fist (see **Shooting Jacket Measurements, 7.5.4.9**).

**7.5.4.2** Closure of the jacket must be only by non-adjustable means e.g. buttons or zippers. The jacket must not overlap more than 100 mm at the closure (see Jacket Table). The jacket must hang loosely on the wearer. To determine this, the jacket must be capable of being overlapped beyond the normal closure by at least 70 mm, measured from the center of the button to the outside edge of the button hole. The measurement will be taken with the arms at the sides. A measurement must be made with an-overlap gauge with a tension of 6.0 kg to 8.0 kg. The area surrounding the button hole is limited to a maximum of 12 mm, and this area may exceed the permitted 2.5 mm thickness.

**7.5.4.3** All straps, laces, bindings, seams, stitching or devices which may be construed as artificial support are prohibited. However it is permitted to have one (1) zipper or not more than two (2) straps to take up loose material in the area of the shoulder pad (see **Shooting Jacket Measurements, 7.5.4.9**). No other zipper or other closing or tightening device is permitted other than those specified in these Rules and Diagrams.

**7.5.4.4** The construction of the back panel may include more than one (1) piece of material provided this construction does not stiffen or reduce the flexibility of the jacket. All parts of the back panel must comply with the thickness maximum of 2.5 mm and the stiffness minimum of 3.0 mm.

**7.5.4.5** The construction of the side panel may not place any seam or seams under the elbow of the support arm in the standing position within a seam-free zone that extends 70 mm above the tip of the elbow and 20 mm below the tip of the elbow. This must be checked with the athlete wearing the jacket fully closed and while holding the rifle in the standing position.

**(USAS Clarification: USA Shooting will not adopt this rule. Any athlete making any USAS Team will be required to comply before any team travel.)**

**7.5.4.6** The athlete must be capable of fully extending both arms (straighten sleeves) while wearing the buttoned jacket. In the prone and kneeling positions, the sleeve of the shooting jacket must not extend beyond the wrist of the arm on which the sling is attached. The sleeve must not be placed between the hand or glove and the fore-end of the stock when the athlete is in the shooting position.

**7.5.4.7** No Velcro, sticky substance, liquid, or spray may be applied to the outside or inside of the jacket, pads or shoes and/or floor or



equipment. Roughening the material of the jacket is permitted. Violations will be penalized according to the Rules.

#### **7.5.4.8**

Shooting jackets may have reinforcement patches added only to their outside surfaces subject to the following limitations:

- a) Maximum thickness, including jacket material and all linings: 10 mm single thickness or 20 mm when measured as a double thickness;
- b) Reinforcement may be added on both elbows but must not extend to more than half (1/2) of the circumference of the sleeve. On the arm which holds the sling, the reinforcement may extend from the upper arm to a point 100 mm from the end of the sleeve. The reinforcement on the opposite arm may have a maximum length of 300 mm;
- c) Only one (1) hook, loop, button or similar device may be fastened to the outside of the sleeve or shoulder seam on the sling arm to prevent the sling from sliding;
- d) Reinforcement on the shoulder where the butt plate rests must not be longer than 300 mm in the longest dimension (see Rule 6.5.4.9);
- e) All inside pockets are prohibited; and
- f) One (1) external pocket is permitted, located on the right front side (left front side for left hand athletes) of the jacket. The maximum size of the pocket is 250 mm high from the lower edge of the jacket and 200 mm wide.





### 7.5.4.9

### Shooting Jacket Measurements

Shooting jackets must must comply with the specifications shown in the drawing:

sizes in mm

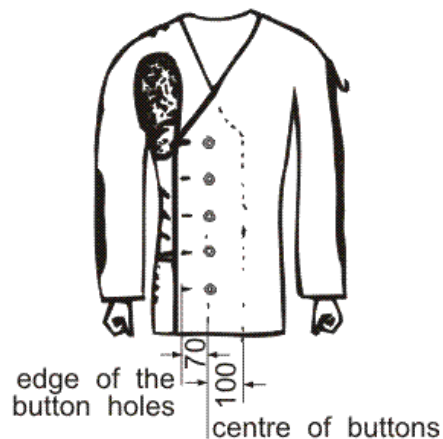
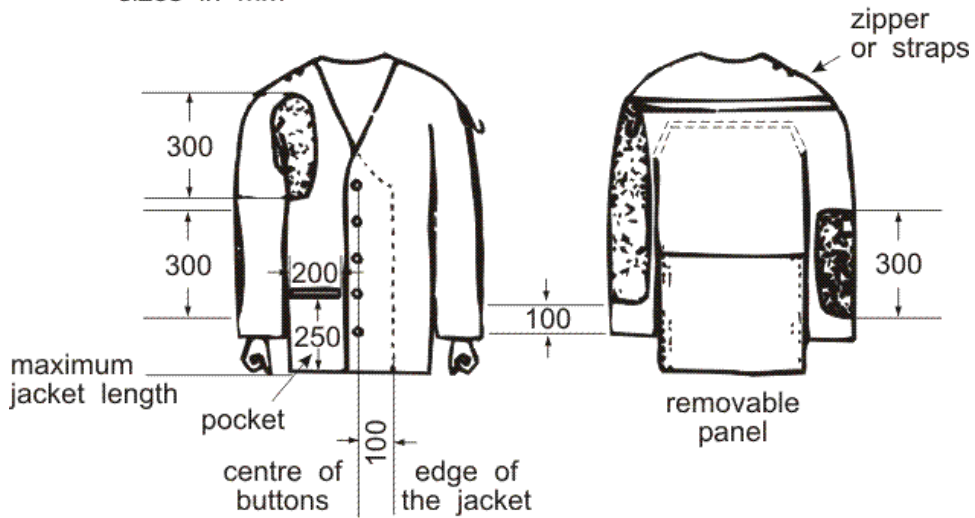

### 7.5.5

### Shooting Trousers

#### 7.5.5.1

The trousers, including the lining, must not exceed 2.5 mm in single thickness and 5 mm in double thickness at any point where flat surfaces may be measured. The top of the trousers must not fit or be worn higher on the body than 50 mm above the crest of the hipbone. All pockets are prohibited. All drawstrings, zippers or fasteners to tighten the trousers around the legs or hips are prohibited. To support the trousers only a normal waist belt not more than 40 mm wide and 3 mm thick or braces (suspenders) may be worn. If a belt is worn in the standing position, the buckle or fastening must not be used to support the left arm or elbow. The belt must not be doubled, tripled etc. under the left arm or elbow. If the trousers have a waistband, it may not be more than 70 mm wide. If the thickness of the waistband exceeds 2.5 mm, a waist belt is not permitted. If a waist belt is not worn, the absolute maximum thickness of the waistband is 3.5 mm. There can be a maximum of seven (7) belt loops, not more than 20mm in width, with at least 80mm between belt loops. The trousers may be



closed by one (1) hook and up to five (5) eyes, or up to five (5) adjustable snap fasteners, or similar closure or Velcro that must not be multilayered. Only one (1) type of closure is permitted. A Velcro closure combined with any other closure is prohibited. The trousers must be loose around the legs. If special shooting trousers are not worn, ordinary trousers may be worn providing they do not give artificial support to any part of the body.

**(USA Shooting Clarification: The seat pad on current trousers may simply be removed to meet this rule.)**

**7.5.5.2** Zippers, buttons, Velcro or similar non-adjustable fasteners or closures, may be used in the trousers only in the following places:

- a) One type of fastener or closure in the front to open and close the trouser fly. The fly must not be lower than the level of the crotch;
- b) Any holes that cannot be closed are permitted; and
- c) Only one (1) other fastener is permitted in each trouser leg. The opening (fastener) must not start closer than 70 mm from the top edge of the trousers. It may, however, extend to the bottom of the trouser leg (see Jacket and Trousers Table). One (1) fastener is permitted either in the front of the upper leg or the back of the leg, but not in both places in one (1) leg.

**7.5.5.3** Reinforcements may be added to both knees of the trousers. Knee reinforcements may have a maximum length of 300 mm and must not be wider than half the circumference of the trousers leg. The thickness of reinforcement including the trousers material and any linings must not exceed 10 mm in single thickness (20 mm double thickness).

**7.5.5.4** Shooting trousers must not be worn in the Rifle Prone events, but they may be worn in the prone stages of Rifle 3 Positions events.

**7.5.5.5 Shooting Trousers Measurements**

Shooting Trousers must comply with the specifications shown in the drawing:

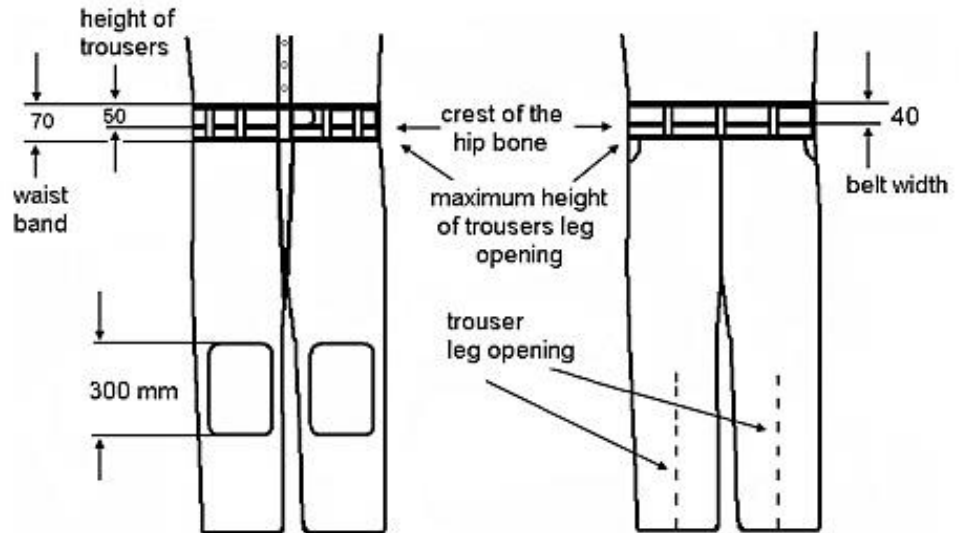

**7.5.6 Shooting Gloves**

**7.5.6.1** The total thickness must not exceed 12 mm when measuring front and back materials together at any point other than on seams and joints.

**7.5.6.2** The glove must not extend more than 50 mm beyond the wrist measured from the center of the wrist knuckle (see drawing). Any strap or other closure device at the wrist is prohibited. However, a portion of the wrist may be elasticated to enable the glove to be put on, but it must leave the glove loose around the wrist.

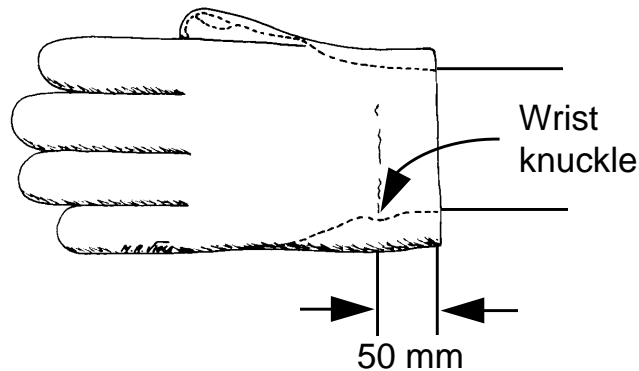

**7.5.7 Underclothing**

**7.5.7.1** Clothing worn under the shooting jacket must not be thicker than 2.5 mm single thickness or 5 mm double thickness. The same applies to all clothing worn under the trousers.

**7.5.7.2** Only normal personal undergarments and/or training clothing that does not immobilize or unduly reduce the movement of the athlete's legs, body or arms may be worn under the shooting jacket and/or trousers. Any other undergarments are prohibited.

**7.5.8 Equipment and Accessories**

**7.5.8.1 Spotting Telescopes**



The use of telescopes not attached to the rifle to locate shots and judge wind is permitted for 50m and 300m events only.

#### **USAS 7.5.8.1A**

The use of telescopes not attached to the rifle to locate shots and to judge the wind is permitted 50m & 300m events only. The use of spotting telescopes is permitted at USAS sanctioned events.

#### **7.5.8.2**

##### **Slings**

Maximum sling width is 40 mm. The sling must be worn only on the upper part of the left arm and from there be connected to the forend of the rifle stock. Slings may be attached to the forend of the rifle at a single point only. The sling must pass along one side of the hand or wrist only. No part of the rifle may touch the sling or any of its attachments except at the sling swivel and hand stop.

#### **7.5.8.3**

##### **Rifle Rests**

The use of a rifle rest for resting the rifle between shots is permitted providing that no part of the stand is higher than the athlete's shoulders when holding the rifle in the standing position. A stand for resting the rifle must not be placed in front of the shooting table or bench in the standing position. Care must be exercised that while resting the rifle, it does not intrude on the athlete on either side. For safety while the rifle is on the rifle rest, it must be held by the athlete.

#### **7.5.8.4**

##### **Shooting Box or Bag**

The shooting box or bag must not be placed forward of the athlete's forward shoulder on the firing line, except that in the standing position a shooting box or bag, table, or stand may be used as a rifle rest between shots. The shooting box or bag, table or stand must not be of such size or construction as to interfere with athletes on adjacent points or to constitute a wind break.

#### **7.5.8.5**

##### **Kneeling Roll**

Only one (1) cylindrically shaped roll is allowed for shooting in the kneeling position. The dimensions are a maximum of 25 cm long and 18 cm in diameter. It must be made of soft and flexible material. Binding or other devices to shape the roll are not permitted.

#### **7.5.8.6**

##### **Kneeling Heel Pad**

A separate piece of flexible, compressible material with maximum dimensions of 20 cm x 20 cm may be placed on the heel in the kneeling position. The kneeling heel pad may be no thicker than 10 mm when compressed with the measuring device used to measure rifle clothing thickness.

#### **7.5.8.7**

##### **Visor or Cap**

A cap or visor may be worn, but it must not touch or rest on the rear sight while the athlete is shooting. The cap or visor may extend forward of the athlete's forehead no more than 80 mm and may not be worn in a way that makes it a side blinder.



## **7.6 SHOOTING EVENT PROCEDURES AND COMPETITION RULES**

### **7.6.1 Shooting Positions**

#### **7.6.1.1 Kneeling**

- a) The athlete may touch the firing point surface with the toe of the right foot, the right knee and the left foot;
- b) The rifle may be held with both hands and the right shoulder;
- c) The cheek may be placed against the rifle stock;
- d) The left elbow must be supported on the left knee;
- e) The point of the elbow must not be more than 100 mm over or 150 mm behind the point of the knee;
- f) The rifle may be supported by the sling but the forend behind the left hand must not touch the shooting jacket;
- g) No part of the rifle may touch the sling or its attachments;
- h) The rifle must not touch or rest against any other point or object;
- i) If the kneeling roll is placed under the right foot or ankle, the foot must not be turned at an angle of more than 45 degrees;
- j) If the kneeling roll is not used, the foot may be placed at any angle. This may include placing the side of the foot and the lower leg in contact with the surface of the firing point;
- k) No portion of the upper leg or buttocks may touch the surface of the firing point or shooting mat at any point;
- l) If the athlete uses the shooting mat he may kneel completely on the shooting mat or may have one (1) or two (2) of three (3) points of contact (toe, knee, foot) on the mat. Other articles or padding may not be placed under the right knee;
- m) Only the trousers and underclothing may be worn between the athlete's seat and heel, except that a kneeling heel pad may be used. The jacket or other articles must not be placed between these two (2) points; and
- n) The right hand may not touch the left hand, left arm or the left sleeve of the shooting jacket or sling.

#### **7.6.1.2 Prone**

- a) The athlete may lie on the bare surface of the firing point or on the shooting mat;
- b) He may also use the mat by resting his elbows on it.
- c) The body must be extended on the firing point with the head toward the target;
- d) The rifle may be supported by both hands and one shoulder only;



- e) The cheek may be placed against the rifle stock.
- f) The rifle may be supported by the sling, but the forend behind the left hand must not touch the shooting jacket;
- g) No part of the rifle may touch the sling or its attachments;
- h) The rifle must not touch, or rest against, any other point or object;
- i) Both forearms and sleeves of the shooting jacket forward of the elbow must be visibly raised from the surface of the firing point;
- j) The athlete's sling (left) forearm must form an angle not less than 30 degrees from the horizontal, measured from the axis of the forearm;
- k) The right hand and/or arm may not touch the left arm, shooting jacket or sling; and
- l) Shooting trousers must not be worn in the Rifle Prone events.

### 7.6.1.3

#### **Standing**

- a) The athlete must stand free, without any artificial or other support, with both feet on the firing point surface or on the shooting mat;
- b) The rifle may be held with both hands and the shoulder or the upper arm near the shoulder and the part of the chest immediately adjacent to the right shoulder;
- c) The cheek may be placed against the rifle stock;
- d) The rifle must not touch the jacket or chest beyond the area of the right shoulder;

**(USAS Clarification:** No part of the rifle or the supporting hand may touch the non-supporting side of the jacket or chest area beyond the center line of the chest.

- e) The left upper arm and elbow may be supported on the chest or on the hip. If a belt is worn the buckle or fastening must not be used to support the left arm or elbow;
- f) The rifle must not touch or rest against any other point or object;
- g) A palm rest may be used but not in 300m Standard Rifle or 10m Air Rifle events;
- h) A hand stop/sling swivel is not allowed in this position for 300m Standard Rifle and 10m Air Rifle;
- i) In this position, the use of the sling is prohibited; and
- j) The right hand may not touch the left hand, left arm or the left sleeve of the shooting jacket.

## 7.7

### **RIFLE EVENTS**

See the **RIFLE EVENT TABLE**, Rule 7.9



**7.7.1 50m and 300m 3 Positions events** must be fired in order:  
**Kneeling – Prone – Standing.**

**(USAS Clarification:** USAS clubs and shooting organizations are welcome to continue to use the event order of Prone, Standing, Kneeling. Block time and the changing of positions throughout the time may not fit the range configuration of many clubs and could pose a safety hazard. USAS will conduct designated National matches in the following format; adequate advance notice will be given on the website and in the match bulletin.)

**7.7.2** A combined 15-minute Preparation and Sighting Time must be provided before MATCH firing starts (Rule 6.11.1.1).

**7.7.3** In 3 Positions events, athletes are permitted to change their targets to Sighting after they complete the kneeling and prone positions. Athletes may fire unlimited Sighting shots before starting MATCH firing shots in the prone and standing positions. No additional time is allowed for these Sighting shots.

**7.8 300m SCORING AND MARKING PROCEDURES – PAPER TARGETS**

**7.8.1** As soon as the Target Marker receives a signal that a shot has been fired on that target, he must indicate the shot. The **indication of shots** must be carried out in accordance with the following system. As soon as the Marker in the pit receives a signal for marking, he must:

- a) **Lower** the target;
- b) **Cover** the hole with a transparent sticker and overlay a contrasting sticker to mark the location of the last shot;
- c) **Raise** the target; and
- d) **Show** the value of the hit by the discing system.

**7.8.2** When a spotting disc is used to indicate shot values, it must be done with a circular disc 200 mm to 500 mm in diameter. It is painted black on one side and white on the other and mounted on a thin staff which is normally fastened on the white side 30 mm to 50 mm to the right of the center.

**7.8.3** The **value** of hits will be shown as follows (see diagram):

- a) The position of the **last hit** must be marked;
- b) The value of hits scoring 1, 2, 3, 4, 5, 6, 7 or 8 points must be shown by placing the disc, **black side toward the firing line**, on the appropriate spot on the target frame in the raised position as shown in the following figure;
- c) If the **hit is a nine**, the disc must be moved up and down twice over the black aiming bulls-eye on the target with the white side of the disc facing the firing line;
- d) If the **hit is a ten**, the disc, with the white side facing the firing line, must be moved twice in a clockwise circle in front



of the black aiming mark, as shown in the following figure;

- e) A shot that does **not hit the target** is marked only by moving the black side of the marking disc three (3) or four (4) times sideways across the face of the target; and
- f) If the hit is on the target card, but **not in the scoring area**, it is marked by first indicating a miss and then by showing the position of the hit.

### Shot Signal Diagram

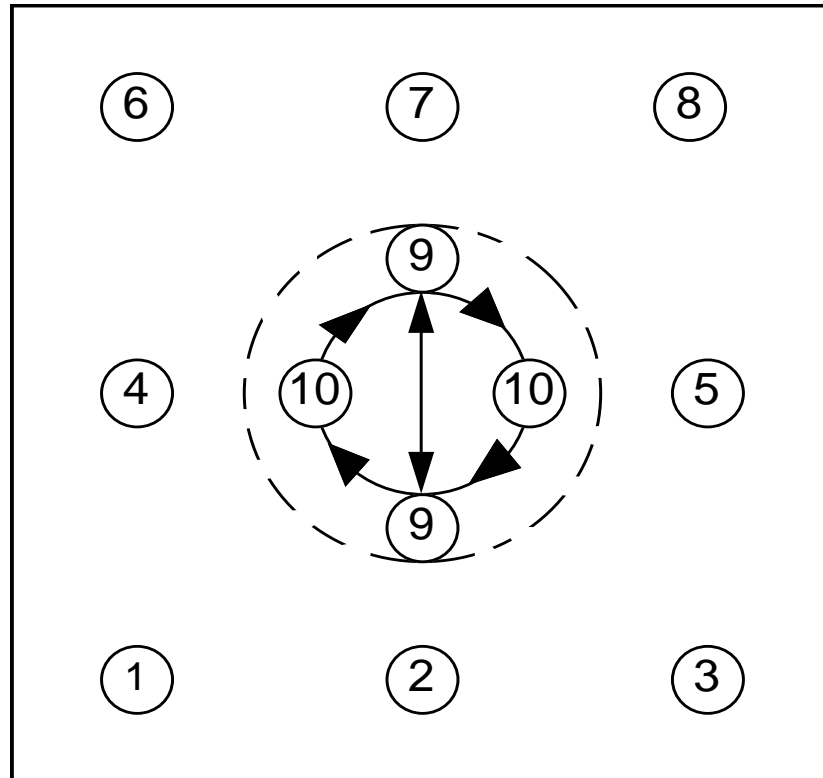

#### 7.8.4

The sighting target must be marked clearly with a black diagonal stripe on the upper right hand corner of the target. The stripe must be clearly visible to the naked eye at the appropriate distance in normal light conditions. In the case of pit operated targets, the sighting target must not appear at all while the athlete is firing MATCH shots.





## 7.9 RIFLE EVENT TABLE

Event	Men/ Women	No. of Shots	Number of Shots Per MATCH Target (paper)	Number of Sighting Targets (paper)	Time: Pit Operated or Target Carriers (when paper targets are used)	Time: Electronic Targets
<b>10m Air Rifle</b>	Men Women	60 40	1	4	1 hour, 30 minutes 60 minutes	1 hour, 15 minutes 50 minutes
<b>50m Rifle 3 Positions</b>	Men	120	1	4 for each position	3 hours, 15 minutes	2 hours, 45 minutes
<b>50m Rifle 3 Positions</b>	Women	60	1	4 for each position	2 hour	1 hour, 45 minutes
<b>50m Rifle Prone</b>	Men Women	60 60	1	4	1 hour	50 minutes
<b>300m Rifle 3 Positions</b>	Men	120	10	1 for each position	3 hours, 30 minutes	3 hours
<b>300m Rifle 3 Positions</b>	Women	60	10	1 for each position	2 hours, 15 minutes	2 hours
<b>300m Rifle Prone</b>	Men Women	60 60	10	1	1 hour, 15 minutes	1 hour
<b>300m Standard Rifle 3 Positions</b>	Men	60	10	1 for each position	2 hours, 15 minutes	2 hours
<b>Note:</b> The combined Preparation and Sighting Time of 15 minutes must start before the published start time of the event.						



**USAS 7.9** **USAS TABLE OF TIME LIMITS** (USAS Clarification: USAS is adopting the new time limit rules, below is a table of time limits USAS will be using in its sanctioned matches.)

<b>3X40 - 50ft</b>		# of Shots	Sighters	Time		
Target Carriers	Prone	40	unlimited			
	Standing	40	unlimited	3 hr 15 min		
	Kneeling	40	unlimited			
Sationary Target Stands	Hang two 10 shot targets	# of Shots Per Stage	unlimited during stage time	Stage Time	# of Stages	Preparation Time after target change
	Prone	20	unlimited	25 min	2	3 min
	Standing	20	unlimited	37 min	2	3 min
	Kneeling	20	unlimited	31 min	2	3 min
	Hang one 10 shot target	# of Shots Per Stage	unlimited during stage time	Stage Time	# of Stages	Preparation Time after target change
		10	unlimited	13 min	4	3 min
		10	unlimited	19 min	4	3 min
		10	unlimited	15 min	4	3 min



<b>3X20 - 50ft</b>		# of Shots	Sighters	Time		
Target Carriers	Prone	20	unlimited	2 hr		
	Standing	20	unlimited			
	Kneeling	20	unlimited			
Stationary Target Stands	Hang two 10 shot targets	# of Shots Per Stage	unlimited during stage time	Stage Time	# of Stages	Preparation Time after target change
	Prone	20	unlimited	25 min	1	3 min
	Standing	20	unlimited	45 min	1	3 min
	Kneeling	20	unlimited	37 min	1	3 min
	Hang one 10 shot target	# of Shots Per Stage	unlimited during stage time	Stage Time	# of Stages	Preparation Time after target change
	Prone	10	unlimited	13 min	2	3 min
	Standing	10	unlimited	19 min	2	3 min
	Kneeling	10	unlimited	15 min	2	3 min



<b>Air Rifle</b>						
	Hang two 10 shot targets	# of Shots Per Stage	unlimited during stage time	Stage Time	# of Stages	Preparation Time after target change
	Women	20	unlimited	30 min	2	3 min
	Men	20	unlimited	30 min	3	3 min
	Hang one 10 shot target	# of Shots Per Stage	unlimited during stage time	Stage Time	# of Stages	Preparation Time after target change
	Women	10	unlimited	15 min	4	3 min
	Men	10	unlimited	15min	6	3 min



7.10

**RIFLE SPECIFICATION TABLE**

Event	Maximum weight	Trigger	Maximum Length of the barrel/system	Ammunition	Thumb hole, thumb rest, palm rest, heel rest, spirit level	Other specifications
<b>10m Air Rifle</b>	5.5 kg (men/women)	No set trigger	850 mm (system)	4,5 mm (.177")	No	No bipod
<b>50m Rifle 3 Positions and Prone</b>	8.0 kg (men)	No restriction	No restriction	5.6 mm (.22") Long Rifle	Yes – palm rest only standing	
<b>50m Rifle 3 Positions and Prone</b>	6.5 kg (women)	No restriction	No restriction	5.6 mm (.22") Long Rifle	Yes – palm rest only standing	
<b>300m Rifle 3 Positions and Prone</b>	8.0 kg (men)	No restriction	No restriction	Maximum 8 mm	Yes – palm rest only standing	Maximum width of mirage band = 60 mm.
<b>300m Rifle 3 Positions and Prone</b>	6.5 kg (women)	No restriction	No restriction	Maximum 8 mm	Yes – palm rest only standing	Maximum width of mirage band = 60 mm.
<b>300m Standard Rifle 3 Positions</b>	5.5 kg (men)	No set trigger Minimum trigger pull: 1500g	762 mm (barrel)	Maximum 8 mm	No	Maximum width of mirage band = 60 mm. No bipod or attached rifle rest.
<b>Note:</b> The rifle must be weighed with all accessories (including palm rest or hand stop if used).						



## 7.11

## INDEX

10m Air Rifle	7.4.4
3 Positions – Firing order	7.7.2
3 Positions – Combined Preparation Time	7.7.3
3 Positions – change targets after a position	7.7.4
300m Rifle	7.4.5 / 7.10
300m Standard Rifle	7.4.3
50m Rifle	7.4.5
50m Rifles for men / women	7.1.4
Accessories	7.5.8
Addition to stock 300m Standard Rifle and 10m Air Rifle	7.4.2.3
Aiming left – Shooting right / aiming right – shooting left	7.4.1.5
Ammunition	7.4.6
Application of Rules for all Rifle events	7.1.1
Barrel – length – 300m Standard Rifle	7.4.3
Barrels	7.4.1.4
Blinder – On the rear sight	7.4.1.5
Butt plate – 50m Rifle / 300m Rifle	7.4.5.1
Butt plate – Offset on 300m Standard Rifles / 10m Air Rifles	7.4.2.1
Caps or Visor	7.5.8.7
Change or more than one part of a rifle per event	7.4.1.1
Change a rifle after disabled	7.4.1.1
Characteristics of shooting clothing	7.5.1.3
Check after competition / qualification (Rule 6.7.0.2)	7.5
Clothing under the jacket and trousers	7.5.7
Clothing under the jacket and trousers Regulations/ Measurements	7.5.2
Compensators	7.4.1.4
Correcting lenses	7.4.1.5
Correction glasses	7.4.1.5
Device inside barrels / tubes	7.4.1.4
Dressing the athlete (Rule 6.7.6)	7.5.1.8
Electronic triggers	7.4.1.6
Rifles and Ammunition	7.4
Follow-up controls after competition / qualification (Rule 6.7.9.1)	7.5
General Rifle	7.6
Heel rest – 300m Standard Rifle / 10m Air Rifle	7.4.2.2
Hook – 50m Rifle / 300m Rifle	7.4.5.1
Immobilize or reduce the movement	7.5.5.1
Increased grip material – 300m Standard Rifle / 10m Air Rifle	7.4.2.5
Indication of shots 300m – paper targets	7.8
Kneeling	7.6.1.3
Kneeling heel pad	7.5.8.6
Kneeling roll	7.5.8.5
Knowledge of the Rules	7.1.2
Left-handed athlete – Right-handed athlete	7.1.3
Length of barrel – 300m Standard Rifle	7.4.2.3
Length of rifle system – 10m Air Rifle	7.4.2.3
Lenses	7.4.1.5



Light filters	7.4.1.5
Manipulation of material after examination	7.5.1.7
Manipulation of material before or during the follow-up controls	7.5.1.6
Material for shooting jackets, shooting trousers, shooting gloves	7.5.1.3
Measuring Devices Gauges Instruments (Rule 6.5)	7.5
Men's events	7.1.4
Movement or Oscillation Reduction Systems	7.4.1.2
Muzzle brakes	7.4.1.4
Number of failures of shooting clothes at the equipment control	7.5.1.6
Number of shooting jackets, shooting shoes and shooting trousers	7.5.1.4
One Rifle per event	7.4.1.1
One-time inspection	7.5.1.3
Palm rest – 300m Standard Rifle / 10m Air Rifle	7.4.2.2
Palm rest – 50m Rifle / 300m Rifle	7.4.5.2
Perforation of barrels / tubes	7.4.1.4
Permanent alteration of clothing	7.5.1.6
Pistol Grips	7.4.1.3
Pistol Grip Extension	7.4.2.4
Positions	7.6.1
Program Order	7.7.2
Prone	7.6.1.1
Range and Target Standards	7.3
Reinforcements – Shooting jacket	7.5.4.8
Reinforcements – Shooting trousers	7.5.5.3
Reinforcements – Table	7.5.2.1
Removing from the firing line – 300m Standard Rifle	7.4.3
Rests – Rifle Rests	7.5.8.3
Rifle 3 Positions Change targets after each position	7.7.3
Rifle 3 Positions Combined Preparation and Sighting time	7.7.3
Rifle Events - See the Rifle Event Table 7.9	7.7
Rifle Measurements Table – 300m Standard Rifle / 10m Air Rifle	7.4.3.2
Rifle Measurements – 300m Standard Rifle / 10m Air Rifle	7.4.4
Right-handed athlete – Left-handed athlete	7.1.3
Safety	7.2
Scoring Procedures – Indication of shots 300m	7.8
Shooting box / shooting bag	7.5.8.4
Shooting Events Procedures and Competition Rules	7.6
Shooting gloves	7.5.6
Shooting gloves – Closure	7.5.6.2
Shooting gloves – Thickness	7.5.6.1
Shooting jacket	7.5.4
Shooting jacket – Artificial support; straps, laces, stitching, etc...	7.5.4.3
Shooting jacket – Body, sleeves, length	7.5.4.1
Shooting jacket – Closure: non-adjustable	7.5.4.2
Shooting jacket – Construction of the back panel	7.5.4.4
Shooting jacket – Drawing	7.5.4.9
Shooting jacket – Fastening of sling	7.5.4.8
Shooting jacket – Loose material in the area of the shoulder	7.5.4.3
Shooting jacket – Overlapping, hanging loosely	7.5.4.2



Shooting jacket – Pocket	7.5.4.8
Shooting jacket – Position of the sleeve	7.5.4.1
Shooting jacket – Both arms straiten sleeves	7.5.4.6
Shooting jacket – Reinforcements	7.5.4.8
Shooting jacket – Reinforcements: butt plate rest on the shoulder	7.5.4.8
Shooting jacket – Reinforcements: elbows	7.5.4.8
Shooting jacket – Reinforcements: maximum thickness	7.5.4.8
Shooting jacket – Roughening	7.5.4.7
Shooting jacket – Side panel with horizontal seams	7.5.4.5
Shooting jacket – Straighten sleeves	7.5.4.6
Shooting jacket – Size of pocket	7.5.4.8
Shooting jacket – Use of sticky substance, liquid, etc...	7.5.4.7
Shooting left – Aiming right / shooting right – aiming left	7.4.1.5
Shooting shoes	7.5.3
Shooting shoes – Drawing and table	7.5.3.6
Shooting shoes – flexibility of the soles	7.5.3.3
Shooting shoes – Height	7.5.3.6
Shooting shoes – Inner soles	7.5.3.2
Shooting shoes – Matched pair	7.5.3.5
Shooting shoes – Material sole	7.5.3.6
Shooting shoes – Material upper part	7.5.3.6
Shooting shoes – Walking test	7.5.3.3
Shooting trousers	7.5.5
Shooting trousers – Braces (suspenders)	7.5.5.1
Shooting trousers – Closure devices	7.5.5.1
Shooting trousers – Closure devices: trousers fly	7.5.5.2
Shooting trousers – Closure devices: trousers leg	7.5.5.2
Shooting trousers – Drawing	7.5.5.5
Shooting trousers – Draw-strings, zippers, fasteners	7.5.5.2
Shooting trousers – Loose around the legs	7.5.5.1
Shooting trousers – Reinforcements	7.5.5.3
Shooting trousers – Thickness	7.5.5.1
Shooting trousers – Top of trousers	7.5.5.1
Shooting trousers – Waist band: wide, closure devices	7.5.5.1
Shooting trousers – Waist belt	7.5.5.1
Shooting trousers – Waist belt: support the arm or elbow	7.5.5.1
Sights	7.4.1.5
Sights – Lenses, lenses system, light filters	7.4.1.5
Slings	7.5.8.2
Spirit level – 300m Standard Rifle / 10m Air Rifle	7.4.2.2
Spotting telescopes	7.5.8.1
Standards for 300m Standard Rifle / 10m Air Rifle	7.4.2
Standards for all Rifles	7.4.1
Standing	7.6.1.2
Stiffness	7.5.2.2
Telescopes	7.5.8.1
Temporarily alteration of clothing	7.5.1.6
Thickness	7.5.2.1
Thickness – Table	7.5.2.1





Thumb hole – 300m Standard Rifle / 10m Air Rifle	7.4.2.2
Thumb rest – 300m Standard Rifle / 10m Air Rifle	7.4.2.2
Trigger Pull – 300m Standard Rifle	7.4.3
Weights – 300m Standard Rifle / 10m Air Rifle	7.4.2.6
Women's events	7.1.4

